

SPECIFICATIONS AUREL ALS200.3 CO₂ LASER SYSTEMS

ALS200 CO₂ LASER SYSTEM

LASER GENERATOR

Wavelength:	10.6 μm
Rated power:	350 W (continuous mode)
Peak output power:	850 W
Power stability (long term):	$\pm 4\%$
Mode quality:	1.1 M^2
Pulse width range:	2 \div 1.000 μs
Pulse frequency:	up to 50 kHz
Gas mix consumption:	< 24 NI/year (cartridge)
Heat dissipation:	5 kW max

On request are available other generators

X-Y TABLE

Stroke:	300 x 300 mm (other strokes on request)
Linear motors	
Optical linear encoders	
Speed:	up to 500 mm/s
Resolution:	0.1 μm
Accuracy:	$\pm 5 \mu\text{m}$
Repeatability:	$\pm 4 \mu\text{m}$

OPERATING REQUIREMENTS

Power:	230V/1ph/50Hz
Compressed air pressure:	5 bar, consumption: 100 NI/min
Exhaust flow rate:	approx. 3 m ³ /min; 1500 mm H ₂ O
Cooling water:	20 \pm 1°C, flow 10 \pm 12 l/min (optional water chiller)

DIMENSIONS AND WEIGHT (*)

Dimensions:	980W x 2.600L x 1.800H mm
Weight:	approx. 1.600 kg

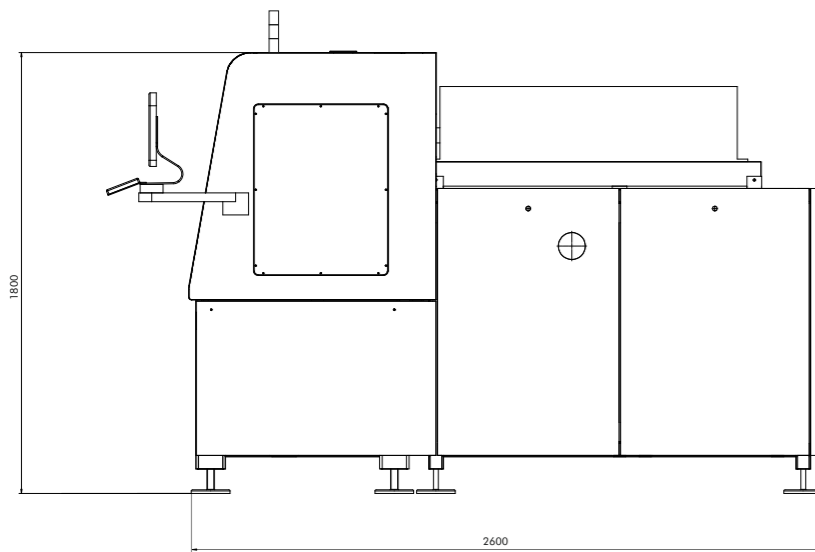

(*) Dimensions and weight can change for special/custom request.

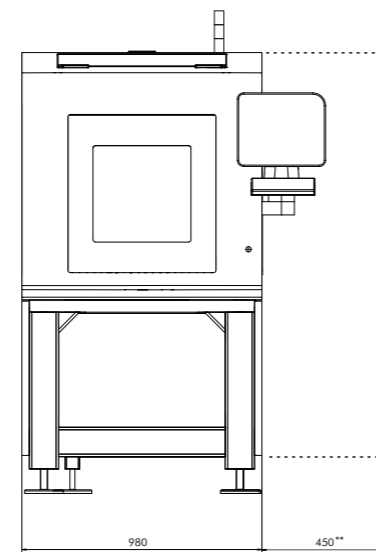

(**) With autoloader system.



The AUREL ALS200 CO₂ Laser System has been designed for scribing, drilling and cutting of ceramic substrates for thin film and thick film hybrid circuits.

The system is compact, reliable, safe and easy to use and it mainly consists of the Laser Mainframe with semi-sealed RF excited CO₂ laser source, high precision X-Y table with linear motors and the Electronic Control on standard PC with menu program for cutting, drilling and scribing.

Special automation and handling are available.



Specification are subject to change without prior notice.

Printed in Italy by EDIT - FAENZA 54A1213

LASER SOURCE

- Gas (CO₂) plasma tubes mounted on a frame with a granite plane to ensure high output power stability.
- RF excitement technology, high peak power, high frequency modulation, compactness.
- No factory service requirement of the self refilling solution, the small internal gas cartridge is extremely easy to change at extraordinary low cost.
- Frequency and pulse width programmable and real-time controlled by the electronic control.

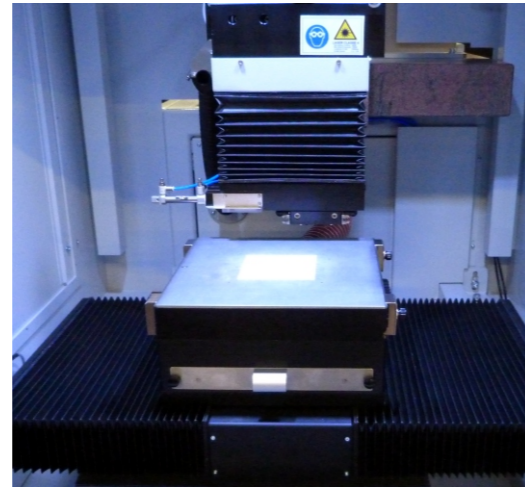

CLOSE-UP OF THE WORK AREA

OPTICAL HEAD

- Focusing group with 30 mm vertical adjustment (autofocus optional).
- Gas jet nozzle for lens protection.
- Exhaust hood for ceramic particles.
- Two nozzles head for scribing and drilling.

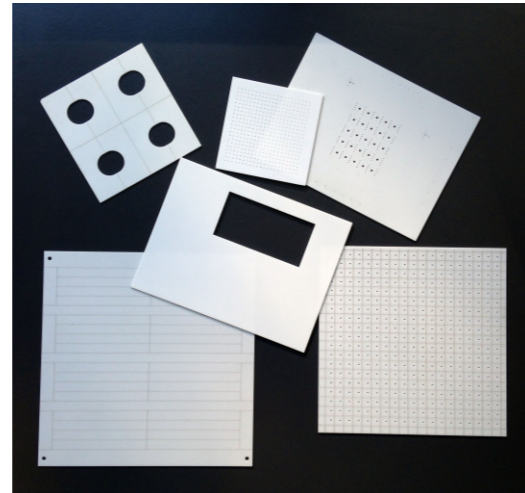

WORKING EXAMPLE

X-Y POSITIONING TABLE

- Driven by high precision fast linear motors with optical linear encoders.
- Maximum stroke 300 x 300 mm.
- The chuck system accepts substrates up to 6" x 6".

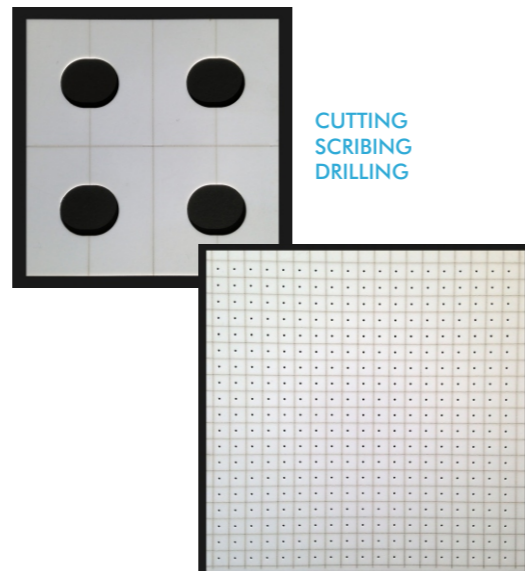

CUTTING
SCRIBING
DRILLING

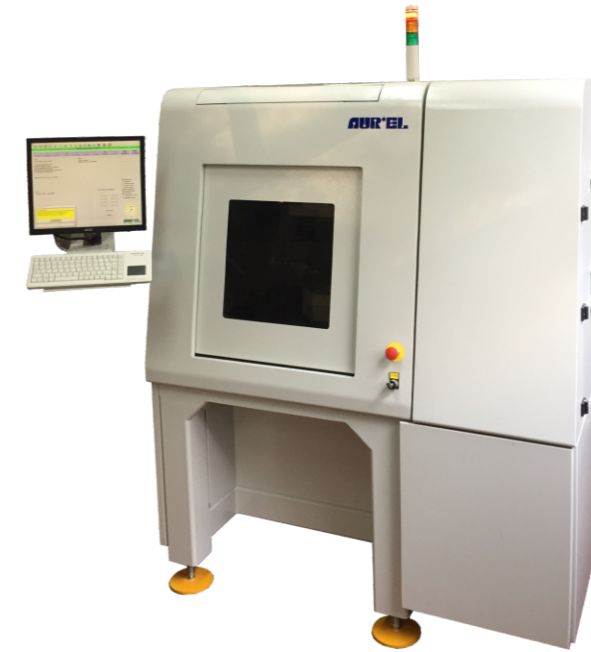

MACHINE WITH AUTOMATIC LOADING & UNLOADING SYSTEM

ELECTRONIC CONTROL

- Based on Windows PC with axes control card (CNC control on request).
- Menu program for cutting, drilling and scribing (linear and circular interpolation).
- Digital I/O for controlling special automations and handling optional.

OTHER OPTION

- Substrate holder with vacuum chamber.
- Vision with electronic cross-hairs.
- Vision with automatic alignment system.
- Automatic loading and unloading systems (stack to stack for blank substrates, cassette to cassette for printed & fired substrates). Shuttles with two or more magazines or multicassette system.
- Exhaust aspiration and filtering.
- Water chiller.



HANDLING SYSTEM