



## FORCED CONVECTION REFLOW SOLDERING SYSTEMS SERIES AF



Models AF5B and AF8B are a new design reflow ovens for SMD with the introduction of all the improvements for LEAD FREE soldering technology.  
High power for an excellent heating distribution and precision, Higher soldering temperature, better cooling system with the combination of Curtains-Fans-Chiller.  
Air or Nitrogen. Conveyor with meshed Belt or Belt-Fingers.

4+4 or 7+7 zones Top and Bottom Heating full convection modules, long life blowers, long life and low consumption heating elements, modular design for easy service and cleaning. New design for Lead Free.

Cooling zone with air/nitrogen blowers, fan ventilators, And air/water heat exchanger, exhaust aspiration, optional exhaust filtering 99,9% efficiency.

Entrance with adjustable barrels, curtains, aspiration chamber.

Computer control with user-friendly software, Windows XP operating system, Temperature PID control, 1000 program storage. Alarms for over temperature, heaters-blowers-thermocouples failure, conveyor stop and muffle open. Week timer. Light tower for status indication.



Pin Chain/Mesh Belt conveyor.

450mm Stainless steel mesh belt conveyor or (optional) combination Pin Chain/Mesh Belt conveyor, width 50-330mm adjustable by hand wheel or motor (optional), SMEMA interface.

Controls for Air/Nitrogen, RS232 port for printer and for external temperature profiler (optional).

Easy access to the machine hardware, removable panels, gas and pneumatic cylinders for complete opening of the muffle, UPS for product evacuation (optional), emergency stop buttons, Interlock switches for total security, easy installation and moving by adjustable feet and wheels.

## AF 5- AF8 Reflows

## Specifications

	AF5	AF8
Conveyor Belt width	450mm	
Pin-Chain Conveyor width	50-330mm	
Speed range	0-2000mm/min	
Average speed	500mm/min	800mm/min
Temperature	Up to 300°C	
Heating Length	1500mm	2600mm
Heating Zones	4+4	7+7
Cooling zone	300mm	
Heat – up – time	30min	40min
Power installed	32kW	64kW
Max electrical input (warm-up)	16kW	28kW
Average rating	8-12kW	14-20kW
Approx weight	400kg	550kg
Utilities	380V 3/N 50Hz	
Air	5 atm – 150 l/min	
Water	1-2 lt/min	

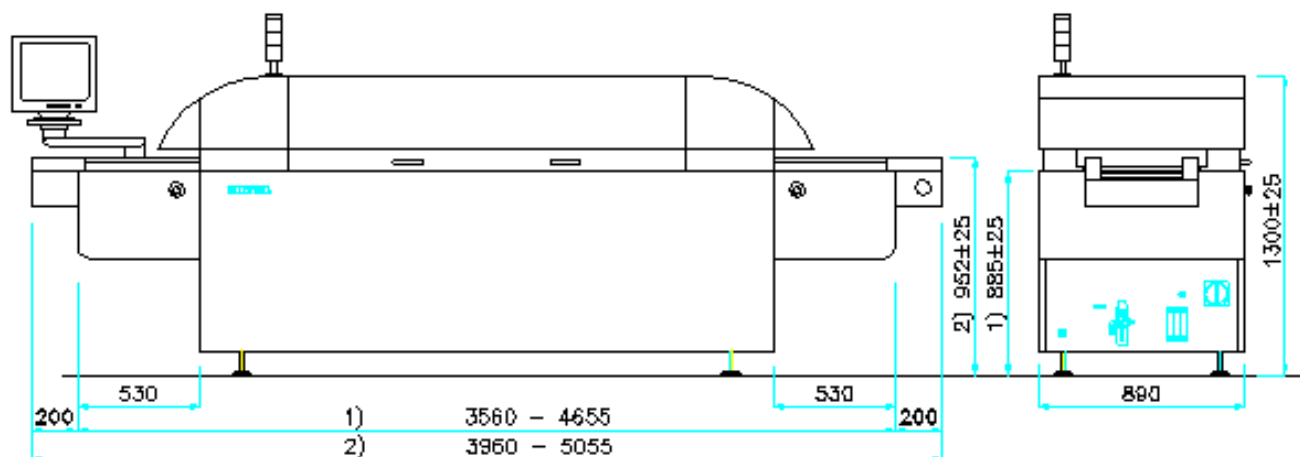

- 1) AF5-AF8 with belt conveyor
- 2) AF5-AF8 with belt/fingers conveyor

specification are subject to change without prior notice.

