

XCEL Systems AUREL WORK CELL



The XCEL is an In-Line or Stand-Alone work cell for Dispensing, Ink Jet, Optical Inspection, Assembly, Soldering, etc..

The applications are in Thick Film, LTCC, polymeric, glass and wafers, for display, solar cell, sensors and biosensors, RFID smart card and polyester foils.

High precision X –Y axis with 5 μ m repeatability.

Technical specification XCEL

Substrate dimension : 50x50mm – 450x500mm fixed by Vacuum on the table
Board thickness : 0.2mm – 5mm
Clearance from board : top 20mm; bottom 0 – 50mm
X – Y axis : max speed 600mm/sec; repeatability error $\pm 5\mu\text{m}$
OS : Windows XP prof English
Power supply : 240V 50Hz 800W
Compressed air : 5 atm 10l/min
Temperature : 15 – 30°C, 5 – 80% RH
Dimensions : 1000 x 1300 x 1450H
Weight : 500 kg

Optional

Z axis : max 50mm/sec; repeatability error $\pm 5\mu\text{m}$
 Θ axis : max speed 1,5°/sec; repeatability error $\pm 0,0014^\circ$
Bottom lighting for ceramic, foils, glass.
Special fixtures

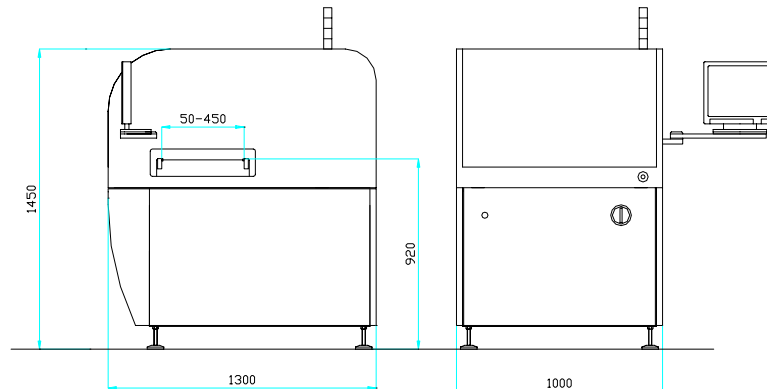

specification are subject to change without prior notice.



XCEL AOI

The AOI45 is an In-Line or Stand-Alone machine for the automatic inspection of printed substrates.

The applications are in Thick Film, LTCC, polymeric, glass and wafers, for display, solar cell, sensors, RFID smart card and polyester foils.

Printed materials to be inspected are conductor dielectric, resistor and solder pastes.

By means of PPI software, the machine checks all defects: dimension of the printed track and pad, quality, continuity, gap between the fine lines, position and tolerance of the different layers.

View area	: standard 30x23mm; optional i.e. 40x30mm, 20x15mm with higher or lower resolution
Resolution	: 30 µm with standard view area
Lighting system	: white led flashed
Camera	: digital color CCD 1024 x 768 pixel
Inspection Output	: good / no good signal, Marking pen, Data file, Display on monitor, print on paper
Speed	: 20 frames/sec
<u>Optional</u>	
High speed software	: 30 frames/sec